



**On the Blowout Preventer Testing Problem: An  
approach to checking for leakage in BOP networks**

Diptesh Ghosh

**W.P. No. 2012-01-02**  
January 2012

The main objective of the Working Paper series of IIMA is to help faculty members, research staff, and doctoral students to speedily share their research findings with professional colleagues and to test out their research findings at the pre-publication stage.

INDIAN INSTITUTE OF MANAGEMENT  
AHMEDABAD – 380015  
INDIA

# ON THE BLOWOUT PREVENTER TESTING PROBLEM: AN APPROACH TO CHECKING FOR LEAKAGE IN BOP NETWORKS

Diptesh Ghosh

## Abstract

Blowout Preventers (BOPs) and choke manifolds are key pieces of drilling rig equipment to prevent the uncontrolled release of potentially hazardous formation fluids to surface. The blowout prevention testing problem is that of testing BOP valves to check if they are functional or not. Several type of testing is done on these valves. This paper deals with the check if the valves are capable of holding pressure. We present a decision model that allows a structured and time saving approach to minimize the number of test sets in order to identify leakage. Recently the BOP terminology has gained prominence and public attention as a result of the Macondo blow-out and resulting oil-spill in the Gulf of Mexico off the coast of the USA.

**Keywords:** BOP testing; network model; leakage testing

## 1 Introduction

The primary function of an oil rig is to search for and develop oil and gas fields by drilling holes (wells). Through these wells, companies can extract crude oil and/or natural gas from geological formations under the earth's surface. These wells are like hollow shafts through the layers of soil and rock, which make up the outer layer of the Earth's crust and into the porous rocks in the formation, which contain crude oil and natural gas. This target formation is called the reservoir and the oil and/or gas is the reservoir fluid. These reservoir fluids can be under high pressure inside the reservoir and would naturally flow upward. This upward pressure exerted by the formation fluids is during the drilling process balanced by careful use of a drilling mud, which is circulated through the well using mud pumps. If the pressure balance between drilling mud and formation fluids is disturbed, it is possible that a certain amount of formation fluids enters into the well (called an influx). If left unattended the influx is released up the drilling shaft (well). When this pressure imbalance continues, allowing more and more formation fluids to enter the well replacing the drilling mud by pushing that out of the well, it is called a blowout. Blowouts can cause severe damage to the rig (See Westergard, 1987), the environment, and to the drilling company's reputation.

Blowout Preventers (BOPs) and choke manifolds are two key pieces of drilling-rig equipment to prevent and combat these possible uncontrolled releases of hazardous (oil and/or gas) formation fluids into the well and eventually making it to surface. They consist of high pressure valves which can be closed rapidly to contain and halt any unwanted influx from a well-bore and then reconfigured in order to divert the influx through a choke and away from the rig in a safe and controlled manner.

Once control of a well is regained, the valves are returned to their original configuration so that normal operations can continue. In modern oil rigs blowout prevention is achieved through multiple BOPs and choke manifold valves arranged primarily in a series-parallel network. The advantage of this series-parallel structure is contingency and back-up so that if any of the valves leak, fail or wear-out, the system can be reconfigured to continue to deal with the influx in a controlled fashion while the leaking or worn valves can be repaired or replaced. Typical blowout prevention networks have between 10 and 50 high pressure valves.

## 2 The Blowout Prevention Testing Problem

The blowout prevention testing problem (BOTP) is that of testing BOP valves to check if they are functional or not. Several types of testing are done on these valves. These include tests on the physical integrity of the valves, tests to check if the valves open when required, and tests to check if the valves are capable of holding pressure, i.e., whether they prevent oil and/or gas from flowing through them when they are closed. This paper deals with this last type of tests. A particular part of the BOP set-up is the Choke Manifold (see Figure 1 for a schematic for an actual choke manifold).

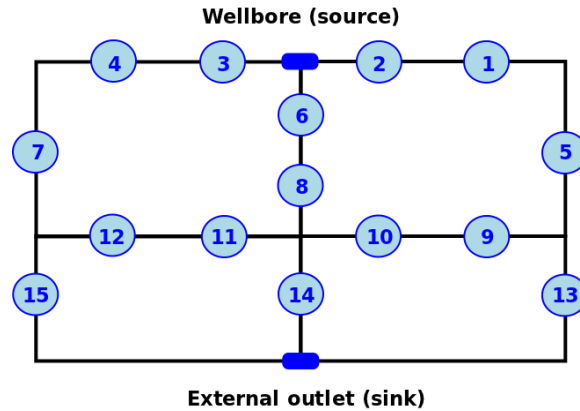

Figure 1: Schematic diagram for a choke manifold

The figure displays the schematic of a choke manifold, called a *valve network* in this paper, with 15 valves, each valve connected to at least another valve via a pipe network. A subset of valves is tested at a time. The test involves imposing pressure from the direction of the wellbore (called the *source* node in the network) against the subset of closed valves to ensure they do not leak and can thus be relied on if needed. If they do hold the pressure they are deemed to be functional. If they do not hold the pressure, then the pressure can be observed at the external outlet (called the *sink* node in the valve network).

While the performance of the complete valve network can be tested by closing all the valves and applying pressure at the source node, BOP testing is done with tests involving only a few of the valves. This is done so that in the contingency of the test failing, the defective valve can be quickly isolated. The set of valves that is used for a test is called a *test set*, and BOP testing is done using minimal test sets. A test set is minimal (and can thus be used in BOP testing if it obeys the following conditions.

- Condition 1: Removal of the valves in the set disconnects the network, i.e., deletes all paths from the source to the sink in the valve network.
- Condition 2: There is a path from the source to each valve in the test set that does not use any other valve of the test set.
- Condition 3: There is a path from each valve in the test set to the sink that does not use any other valve of the test set.

So, for example, for the BOP of Figure 1, valves 13, 14, and 15 constitute an allowed test set (see Figure 2). The BOP testing problem is one of determining test sets such that all BOP valves in a valve network are tested at least once. Evaluating test sets are financially expensive and not without risk as the test imitates real life and high pressure scenarios. Currently the network shown in Figure 1 is tested using a sequence of five test sets shown in Figure 3.

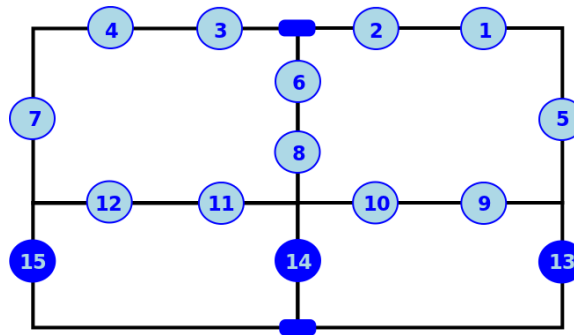

Figure 2: A test set shown as dark nodes

Hence the objective of the BOTP is to determine a set of test sets with minimum cardinality. The problem has not been addressed in the literature to the best of our knowledge. Two related problems have however been studied in the literature. The first is the combinatorial group testing problem (see Du and Hwang, 2000), in which one is required to isolate a subset of elements with certain characteristics from a group of elements using a minimum number of tests. This problem is applied, for example, in isolating blood samples corresponding to AIDS patients within a batch of blood samples. Combinatorial group testing problems differ from the BOTP in that in the former, any arbitrary subset of elements can be tested, while that is not the case in the BOTP. The other problem, addressed in Loulou (1992), constructs a minimum cardinality cover of elements in an electronic board to minimize the effort of testing the functioning of all the components. However, this problem too is not identical to the BOTP since it has no restrictions on the elements that form the sets of the cover.

### 3 The Solution Methodology

In this section we outline the methodology for solving the BOTP, i.e., conducting the minimal number of tests to find out whether all the BOP valves in the valve network are functional. We will use the network in Figure 1 for illustration. We call this network the *original network*. Our method consists of two broad steps, (a) characterizing sets of valves which can form test sets; and (b) using the characterization to generate test sets.

#### Characterizing test sets

The number of valves that make up a BOP network is large enough to discourage checking each combination of valves to find out whether it is indeed a test set is computationally expensive. We therefore need a characterization of the sets of valves that constitute test sets. To do this, we first observe that if a set of valves are in series in the original network, then no more than one of them can be part of a test set. For example, no more than one of the valves 1, 2, and 5 can be present in a single test set for the original network. This observation allows us to replace the BOP valves in the network with equivalent valves. An *equivalent valve* is simply a place-holder which can accommodate one of the set of BOP valves which the equivalent valve is replacing. We call the network of equivalent valves the *reduced network*. Figure 4 represents the reduced network formed by replacing the BOP valves in the original network in Figure 1. For example, the equivalent valve A in the reduced network is inserted by removing BOP valves 3, 4, and 7 in the original network. Each equivalent valve is assigned a *weight* which is the cardinality of the set of valves that it replaces. For example, the weight of valve A is 3 while that of B is 2. The utility of this weight will be apparent in the second step of the method.

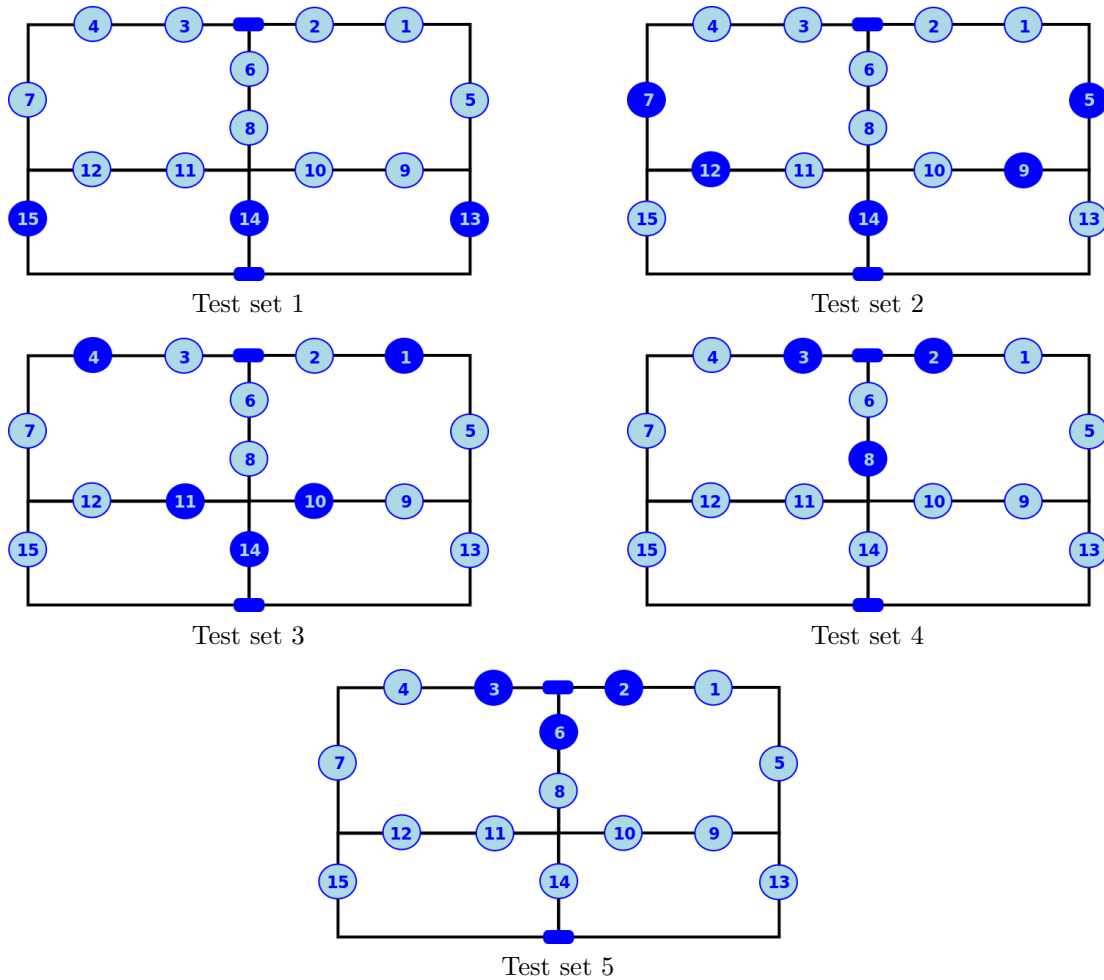

Figure 3: The current test sequence (the dark nodes indicate valves being tested)

Notice that each test set in the original network corresponds to a test set in the reduced network. However, a test set in the reduced network can correspond to multiple test sets in the original network. For example, the test set  $\{A,B,C\}$  in the reduced network corresponds to 18 test sets in the original network. Also since the number of valves in the network of equivalent valves is much lower than the number of BOP valves in the original network, it is possible to enumerate all combinations of valves in the reduced network.

This enumeration is made efficient two ways. First, we can find out the minimum number of composite valves that form test sets. This is the number of composite valve disjoint paths from the source to the sink node in the reduced network. It is computed by setting the capacity of each edge in the network to 1 and finding the maximum flow from the source node to the sink node in the reduced network. The value of this flow is the minimum cardinality of equivalent valves in a test set. For example, in the reduced network in Figure 4, the value of the maximum flow in the is 3 units, which tells us that no test set in the reduced (and hence the original) network can consist of less than 3 valves. Second, we know that the test sets are minimal, so that a set of valves cannot be a test set if a subset of those valves is a test set. For example,  $\{A,B,C,D\}$  cannot be a test set, since  $\{A,B,C\}$  is a test set. Using these two rules we can reduce the enumeration considerably; in the reduced network of Figure 4, there are  $8! = 40320$  possible combinations of composite valves, but our rules allow us to find all test sets by checking only 220 combinations.

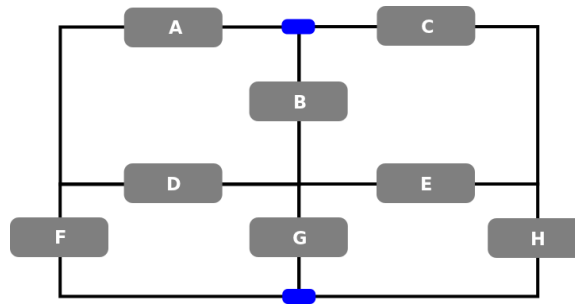

Figure 4: The network of composite valves

Testing whether a set of nodes (i.e., composite valves) constitute a test set is done in three stages. In the first stage, the set of nodes are removed from the network. If this disconnects the source and the sink, then the set satisfies Condition 1 and is a possible test set. It is then subjected to the test in the second stage. Otherwise it is not a test set. In the second stage, the capacities of all connections in the reduced network are set to infinity and all flows starting from the nodes in the candidate test set are disallowed. A dummy sink node is then created and all nodes in the candidate test set are connected to the dummy sink node by arcs with capacity of 1. If the maximum flow from the source node to the dummy sink node in this network is equal to the cardinality of the candidate test set, then the set of nodes obey Condition 2 and is a possible test set. It is subjected to the test in the third stage. Otherwise it cannot be a test set. In the third stage, the alterations made for the second stage are reversed, the capacities of all connections in the reduced network are again set to infinity and all flows to the nodes in the candidate test set are disallowed. A dummy source node is then created and arcs with capacity 1 are set up from the dummy source node to all nodes in the candidate test set. If the maximum flow from the dummy source node to the sink node in this network is equal to the cardinality of the candidate test set, then the candidate set obeys Condition 3 and is a test set. Otherwise it is not.

Using these sets in the reduced network in Figure 4 we observe that there are eight test sets in the reduced network, viz.  $\{A,B,C\}$ ,  $\{A,B,E,H\}$ ,  $\{A,C,D,E,G\}$ ,  $\{A,D,G,H\}$ ,  $\{B,C,D,F\}$ ,  $\{B,D,E,F,H\}$ ,  $\{C,E,F,G\}$ , and  $\{F,G,H\}$ .

The identification of test sets in terms of composite valves allow the following characterization of test sets in terms of BOP valves.

A set of BOP valves forms a test set if its member valves obey two conditions:

1. No two BOP valves in the set are represented by the same equivalent valve.
2. The equivalent valves corresponding to the BOP valves in the set form a test set in the reduced network.

## Generating test sets

We use the characterization described above to generate a set of test sets that check the functioning of every BOP valve in the original network. The set of test sets is first constructed in terms of the equivalent valves, and later the equivalent valves are replaced with BOP valves to obtain the actual test sets.

A set of test sets in terms of equivalent valves have two properties.

1. Each test set in the set must be of a form characterized in the previous section.

2. Since no more than one BOP valve represented by an equivalent valve can be part of a possible test set, and since all BOP valves must be part of at least one test set, the number of times that an equivalent valve appears in the set of test sets is not less than its weight.

Given these properties, the set of test sets in terms of equivalent valves can be obtained using the weighted set covering formulation described below.

#### Indices and data:

$EV = (ev_i)$  is the vector of equivalent valves, and  $i$  is the index used for this vector.  $w_i$  is the weight of equivalent valve  $ev_i$ .  $TS = (ts_j)$  is the vector of test sets, and  $j$  is the index used for this vector.  $M = [m_{ij}]$  is an array with binary entries, where  $m_{ij} = 1$  if test set  $ts_j$  includes equivalent valve  $ev_i$ , and 0 otherwise.

#### Decision variables:

$y_j$  is the number of times test set  $ts_j$  is used in the set of test sets that cover the set of valves in the reduced network such that each equivalent valve  $ev_i$  appears at least  $w_i$  times.

#### Model:

$$\left\{ \text{minimize } \sum_j y_j \mid \sum_j m_{ij} y_j \geq w_i \forall i; y_j \text{ integer } \forall j \right\}.$$

For the reduced network in Figure 4, this model stipulates that four test sets are required ( $\{A,B,C\}$ ,  $\{A,B,E,H\}$ ,  $\{A,C,D,E,G\}$ , and  $\{B,C,D,F\}$ ). This is not a unique optimum solution; another optimal solution involves using test set  $\{A,B,C\}$  twice and each of test sets  $\{A,C,D,E,G\}$  and  $\{B,D,E,F,H\}$  once.

Given the test sets in terms of equivalent valves, test sets in terms of BOP valves are obtained by replacing the equivalent valves in the test set with BOP valves. Suppose an equivalent valve  $ev_i$  occurs  $n_i$  times ( $n_i \geq w_i$ ) in the set of test sets. Then in its first  $w_i$  occurrences, this equivalent valve is replaced by each of its component BOP valves in turn, and in the remaining  $n_i - w_i$  occurrences, the equivalent valve is replaced with any one of its component BOP valves. For example, equivalent valve B has a weight of 2 and it occurs three times in the set of test sets stipulated by the model. In its first occurrence (in  $\{A,B,C\}$ ), it is replaced with BOP valve 6, in its second occurrence (in  $\{A,B,E,H\}$ ), with BOP valve 8, and in its third occurrence (in  $\{B,C,D,F\}$ ), again with BOP valve 8. Such assignments lead to the set of test sets shown in Figure 5. This set covers all BOP valves in four test sets in contrast to the current practice which requires five test sets.

The test sets that are generated by using this model is the minimal set of test sets, since each of the parts of the process is optimal.

## 4 Conclusion

The blowout testing problem (BOTP) is an interesting optimization problem. Apart from being challenging from the optimization standpoint, its solution is strategically important to companies that carry out drilling activities. The exposure of a company to risk, both in terms of money and reputation, is significant in case of blow-outs. A well-publicized example is the recent blow-out of the Macondo well in the Gulf of Mexico which happened in April 2010 (refer to Azwell et al., 2011 for an environmental report on the result of the blowout), which was the result of a sequence of failures, not only related to BOP testing, but also to inefficiencies related to the organization and

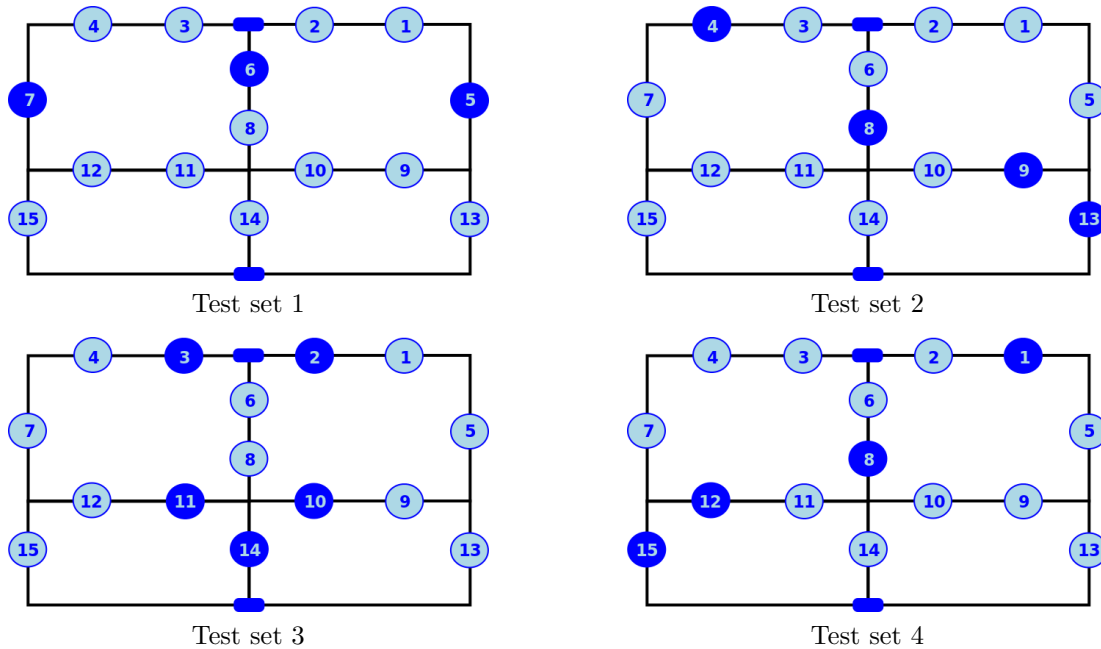

Figure 5: An optimal test sequence (the dark nodes indicate valves being tested)

procedures. Since the testing is done regularly (often fortnightly) and since the testing is expensive (to the tune of USD 10,000 per test set tested), any reduction in the number of required tests significantly reduces cost during the drilling and operation of an oil rig.

In this paper we have method developed to carry out BOP testing using a minimum number of tests. We have demonstrated the use of the method with an example. Our optimization model is also a first step in isolating malfunctioning BOP valves in a BOP valve network. However, the detailed sequence of tests that identify responsible valves in case of a leakage is yet to be obtained.

A practical application demonstrated that the introduction of the model on the rig not only allowed for faster identification of leakage, but also structured the decision making process. It enforced the implementation of a testing strategy, where the people on the rig first ran the model in order to identify leakage, rather than taking ad-hoc decisions and immediate repair actions which could be counter-productive, especially if more than one valve leaked. The drilling manager and drilling supervisor both appreciated the improvement in work process from the introduction of such structured approach towards decision-making as part of the day-to-day practices.

## Acknowledgement

Thanks to Chris Gregory for initially bringing this problem to our attention during one of the rig operations in Papua New Guinea and recognizing this as a challenge where operations research can be useful. Thanks also to Nilotpal Chakravarti, Tony Sucandy, Yosua J. Setyobudhi, Yenny Subhawani, and Peter Serhalawan of New Frontier Solutions Pte. Ltd.; Andre Mol of PI International BV; and Chris Hindmarsh, drilling supervisor and freelance performance consultant.



## References

- [1] Azwell, T, Blum, M.J., Hare, A., Joye, S., Kubendran, S., Laleian, A., Lane, G., Meffert, D.J., Overton, E.B., Thomas, J. III, White, L.E. The Macondo Blowout Environmental Report, Deepwater Horizon Study Group Environmental Report, 2011.
- [2] Du, D., and Hwang, F. Combinatorial Group Testing and Its Applications, World Scientific, Singapore, (2000).
- [3] Loulou, R. Minimal cut cover of a graph with an application to the testing of electronic boards, Operations Research Letters,12 (1992), pp. 301–305.
- [4] Westergaad, R. All About Blowout, Norwegian Oil Review, 1987 ISBN 82-991533-0-1, (1987).